



RELIABLE SAFE ACCESS

Self Closing Safety Gates



- SPRING LOADED TO AUTOMATICALLY CLOSE BEHIND THE USER
- EASY TO ASSEMBLE, CAN BE CUT TO SIZE
- CONSTRUCTED FROM GALVANISED, CORROSION RESISTANT COMPONENTS
- COMPLIANT WITH EN 13374, EN 14122 : 2016 AND OSHA

Self Closing Safety Gates



KEE GATE self closing safety gates are ideal for protecting access and egress on rooftops and in industrial environments. The gates have been designed to easily fit to new or existing structures wherever a gate is required.

Each safety gate is spring loaded so it automatically closes behind the user. This overcomes the potential for human error that is often associated with traditional forms of protection such as chains or bars where incorrect usage can lead to the creation of a hazardous void.

Compliance

KEE GATE safety gates are compliant with EN ISO 14122 Parts 3 and 4 Safety to Machinery. Permanent means of access to machinery, EN 13374 Temporary edge protection systems. and OSHA standards. The gates are also CE marked for assured and safe operation.

Material

The gates are made from galvanised steel and can be supplied powder coated in RAL 1021 (Rape Seed Yellow) for extra visibility.

Easy Installation

KEE GATE self closing gates can be easily installed on new and existing systems and do not require exact measurements before purchasing. The gates can be cut down to size on-site during install, to fit the required opening.

Features and Benefits

- Spring loaded to automatically close behind the user
- Standard 1m wide gate can be cut to size
- Requires no welding on site
- Reversible, hinges can be on the left or right hand side of an opening
- Can be retro-fitted to existing structures
- Can fit different surfaces (round or square)
- Hot dip galvanised or powder coated in safety yellow
- Can withstand loads up to 225Kg
- Life cycle tested to BS 6375-2:2009 Clause 6.5 – Opening and closing of Gate through 90 degrees 50,000 cycles without failure
- Salt spray tested to ASTM B117-11 Neutral solutions over 200 hours
- Industry compliant



Self Closing Safety Gates Installation Guide

Ease of installation has played a major factor in the **KEE GATE** design. Below is a simple installation guide. You can also watch the installation video at <https://keesafety.co.uk/knowledge-centre/videos/kee-gate-installation-video>



1. Open up gate assembly and fit U bolts, washers and nuts. Align fixing plate, ensuring top rail of gate is level with guardrail.



2. Tighten to 25Nm.



3. Measure distance from edge of gate to guardrail upright, and record distance to cut.



4. Remove tubular gate from hinge assembly, by releasing grub screws. Mark recorded distance to cut from open end of gate.

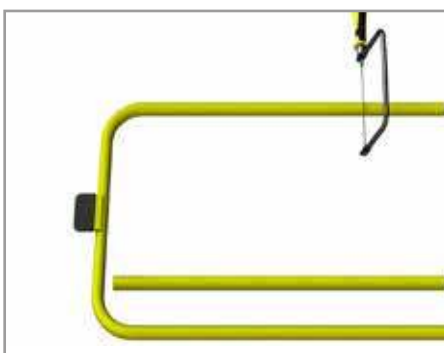

5. Cut through top, bottom and mid rail tubes.



6. Replace tubular gate, and tighten grub screws to 39 Nm.



7. Adjust tension of hinge so gate closes fully, and tighten locking nut.



8. Mount clamps on lower part of gate; attach mid rail to gate.



9. Ensure mid rail is level, and gap between top of gate and mid rail is not greater than 470mm, and torque clamps to 19 Nm.

Self Closing Safety Gates Range

KEE GATE Self Closing Gates provide protection for indoor and outdoor industrial applications including any openings, ladders, stairs, rooftop hatches and controlled areas, where regular access for workers is needed.

Kee Safety offers a full range of self closing safety gates. Our gates are quick and easy to assemble. All types of gates have been independently tested and comply with international standards.

- **Single width gates** for openings up to 1 metre wide
- **Double width gates** for openings greater than 1m (max. width 1.8m)
- **Full height gates** for ladders, designed to comply with EN 4211:Specification for Permanently Fixed Ladders

Part Name	Part Code
SINGLE WIDTH GATES	
Single EU Gate - Galvanised	SGEUGV2
Single EU Gate - Powder Coated	SGEUPC2
DOUBLE WIDTH GATES	
Double Gate - Galvanised	SGEUDGV2
Double Gate - Powder Coated	SGEUDPC2
FULL HEIGHT GATE	
Single Full Height EU Gate - Galvanised	SGEUEFGV
Single Full Height EU Gate - Powder Coated	SGEUFPC

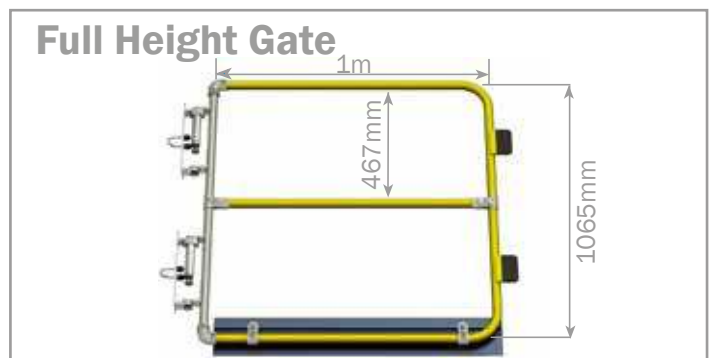
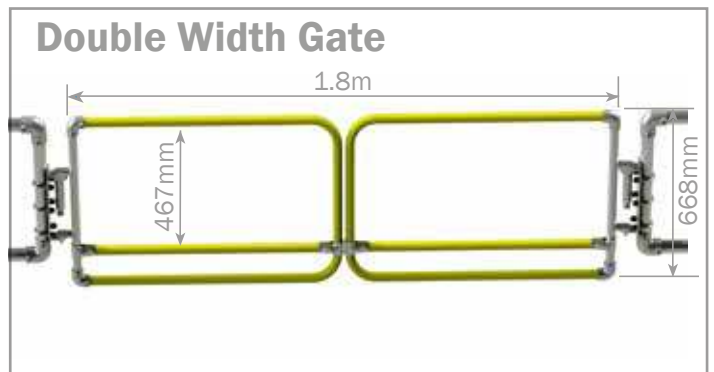
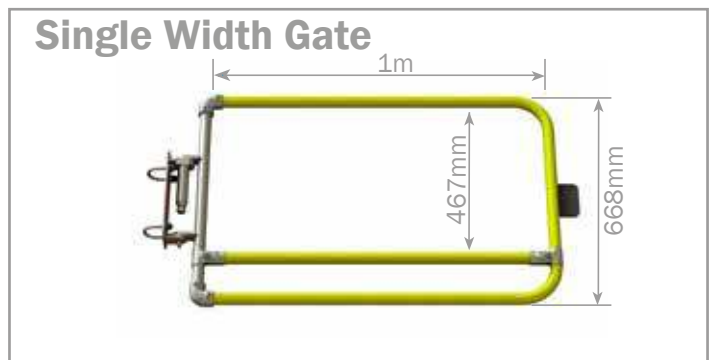

Kee Safety Limited
Cradley Business Park
Overend Road
Cradley Heath
B64 7DW, UK

Tel: +44 (0) 1384 632 188

Fax: +44 (0) 1384 632 192

Email: sales@keesafety.com

Website: www.keesafety.co.uk